

# Trojan 80

## External Venetian Blinds

### Rigid Slat Range

SEC80 Motorised control and side cable.  
SEG80 Motorised control and side guides.  
SRG80 Gearbox control and side guides.  
SRC80 Gearbox control and side cables.

### Flexible Slat Range

FEC80 Motorised control and side cable.  
FRC80 Gearbox control and side cables.



Slat S80

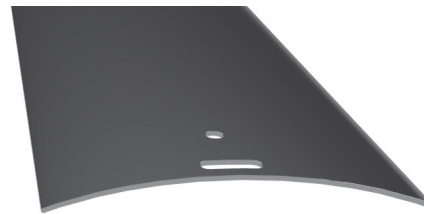

Slat F80

## Technical Specification

### Slats

Made from special grade aluminium alloy that is designed to give the greatest flexibility with maximum resistance to corrosion. They are roll-formed from pre-coated aluminium strip that has been specially treated before enamelling to give maximum bond between metal and the finish. The enamel, in a wide range of colours, is then baked to give a finish highly resistant to scratching, fading and cracking. The profile is 80mm wide x 0.45mm thick with a curved form.

### Head Rail

Roll formed steel section 58mm wide x 56mm deep which conceals the operating mechanism and has a galvanised finish.

### Tilt and Raise Rod

Rigid 14mm round extruded aluminium fitted through tape rolls in the headrail. Of a dimension to ensure minimal deflection across the width.

- 1 Slat
- 2 Headrail
- 3 Bottom Rail
- 4 Ladderbraid
- 5 Lift Tape
- 6 Top Fixing Bracket
- 7 Motor
- 8 Side Guide
- 9 Side Guide Bracket
- 10 Guide Pin

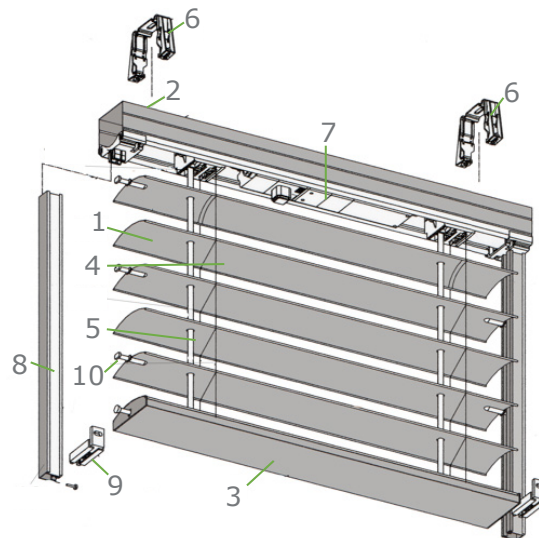

Component Descriptions complying with EN12246



Hallmark Blinds  
173 Caledonian Road  
London, N1 0SL

www.hallmarkblinds.co.uk  
info@hallmarkblinds.co.uk  
Tel: +44 207 837 0964

# Trojan 80

## External Venetian Blinds

**Bottom Rail** Extruded aluminium section 85mm wide x 17mm deep in RAL colour to match the slat. End caps are black or grey.

**Ladderbraid** External grade mini visible Trevira® braid available in black and grey. It is shrinkproof, rotproof and guaranteed fade resistant. Spacing between ladders is 68mm.

**Lift Tape** 6mm wide polyester lift tape in black or grey that is weather, shrink, stretch, break and fold resistant.

### Side Guides

Trojan slats are guided by extruded aluminium sections. All profiles have nylon inserts in both sides of the extrusion as a noise buffer.

- Standard guide ES20 with bracket groove is for face fixing.
- Type RE41 guide has a re-inforced round profile.
- Type EF40 guide is a reinforced profile that allows greater span between fixings.
- Box support guides are particularly suited to retro-fit applications as all of the fixing points are on the side guides. The blind and fascia box are supported on the guides both simplifying the installation procedure and reducing the impact of the assembly on the building structure.

All are available as a centre (double) guide

### Side Guide Pins

Nylon guide pins are fitted to alternate ends of the slats to allow movement of the slatting area. The pins are silver.

### Performance

Trojan 80 meets the performance requirements of EN13561 Class 3 for wind resistance which is Beaufort scale force 6 (strong wind) a wind speed of 49 km/h

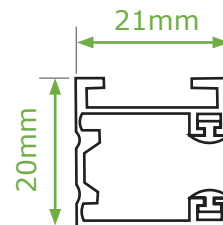

ES20 Standard guide

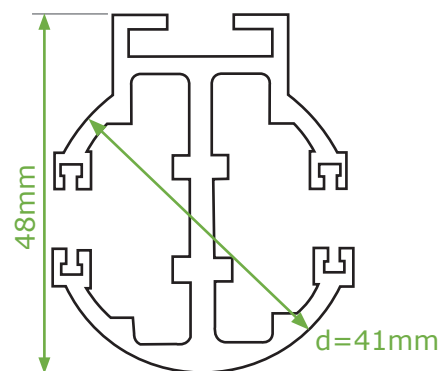

RE 41 Box support guide

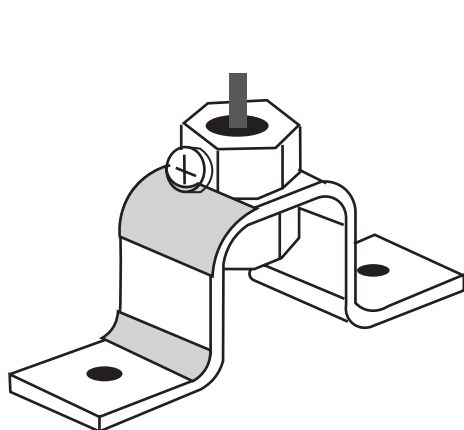

BA25 Cill bracket

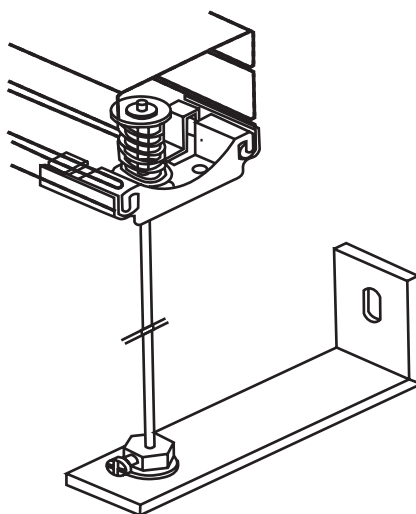

SW40 Face fix bracket

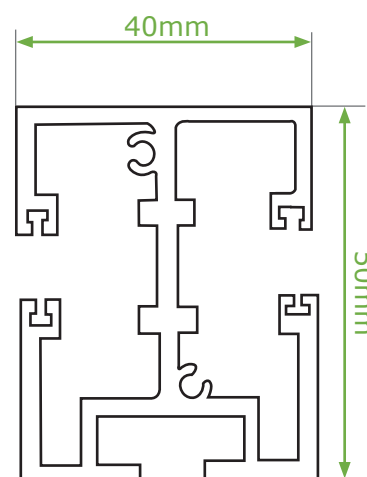

EF40 Box support guide



# Trojan 80

## External Venetian Blinds

### Operation

Trojan blinds are mono controlled with both tilt and raise/lower on one motor or gearbox. The sequence of the operation is that it first tilts to the closed position and then lowers. Reversing the operation causes the blind to first tilt to the opposite closure before raising. Thus the blind can be fully tilted at any point between fully lowered and fully raised by reversing the control. The slat angle can be also factory set to lower in the working (45°) position.

### Motorised Control SEG80, SEC80 FEC80

#### Motors

The motor is located in the blind headrail. It is 240v single phase with a maximum current requirement of less than 1 amp. It is supplied with an 80cm "flying" lead. This should be connected to a junction box or plug adjacent to the headrail to facilitate removal for maintenance. 110v motors are also available.

#### Wiring

The motor has a four core cable Neutral, Earth, Supply for lower and Supply for raise. Wiring diagrams are available for all standard control options.

#### Switches

A range of switches is available. Before using any other type of switch it is important to confirm with us that it is compatible to maintain the motor manufacturers warranty.

### Manual Control FRC80, SRG80 SRC80

Manual operation drive creates a thermal break so it is not suitable for passive house.

#### Gear Box

Hardened steel gears running in Zamac casings which produce a smooth operation which is robust and maintenance free. The unit is located at one end of the headrail.

#### Limit Adjuster

A nylon traveller that if fitted on the tilt shaft with an adjustable stop that is pre-set to prevent damage from over winding.

#### Universal Joint

A drive from the gearbox exits from the back of the headrail through the building to a universal joint. A 20mm hole is required through the building to allow clearance for the drive. The standard joint drive type GP45 exits at 45° to a nickel plated mounting 22mm wide x 85mm high on the room side. A 90° drive type GP90 is also available.

#### Operating Rod

The joint is connected to 15mm dia. rod with a cranked end. A nylon magnetic clip retains the rod when not in use.

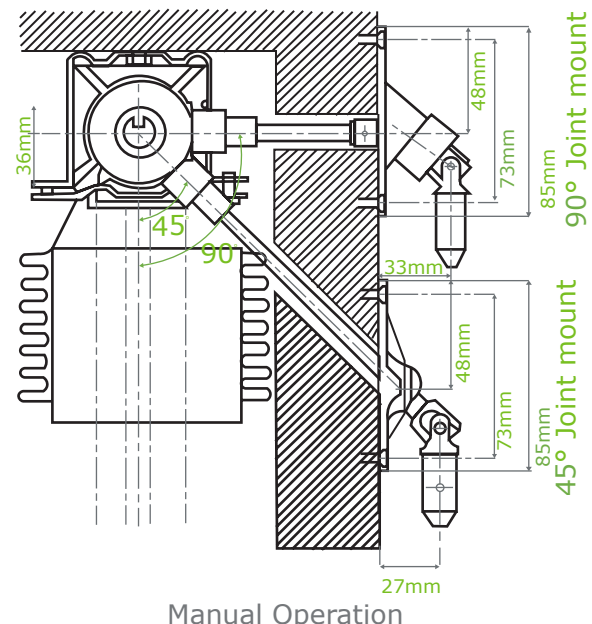

## External Venetian Blinds

Standard Fascia Profiles

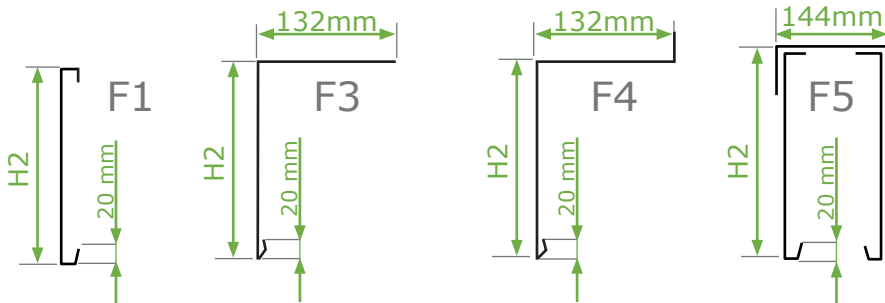

Guide supported

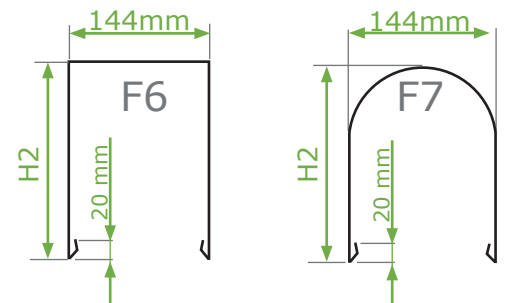

### Boxing or Fascia

Ideally the blind is recessed into an opening above the window head. A minimum opening width of 120mm is required to allow access, this dimension should not be exceeded. The depth required (H1) is shown on the stacking chart. On existing buildings a fascia or box will be required to house the blind when retracted. There are 6 profiles with standard depths (H2). Extruded aluminium boxing is available in styles F6 and F7. This is supported on the side guides. Stacking dimensions and dimensions for blinds in standard boxing.

Dimension Chart				
	Min Width (mm)	Max Width (mm)	Max drop (mm)	Max Sq. Area
FEC80	600	3500	4000	14
FRC80	600	3500	4000	8
SRC80	600	3500	4000	14
SEG80	720	5000	5000	17
SRG80	655	5000	5000	16

Blind Type	SEG80 Guide Support
Guide Support	SRG80 Guide Support
O/A Drop Size (mm)	Cover Height (mm) (H2)
800-1200	240
1200-2800	330
2800-4000	390

Drop size (mm)	Blind type SEC80 - SRC80 SRG80 - SEG80		Blind type FEC80 - FRC80	
	Stacking Height (mm) H1	Standard Boxing or Fascia height (mm) H2	Stacking Height (mm) H1	Standard Boxing or Fascia height (mm) H2
800	190	200	140	150
1000	200	200	150	150
1200	210	250	160	170
1400	230	250	170	170
1600	240	250	180	200
1800	250	250	190	200
2000	260	250	200	200
2200	280	300	210	250
2400	290	300	220	250
2600	300	300	220	250
2800	310	340	230	250
3000	320	340	230	250
3200	340	340	250	250
3400	350	370	260	300
3600	360	370	270	300
3800	370	370	280	300
4000	380	440	290	300
4200	400	440		
4400	410	440		
4600	420	440		
4800	430	440		
5000	440	440		

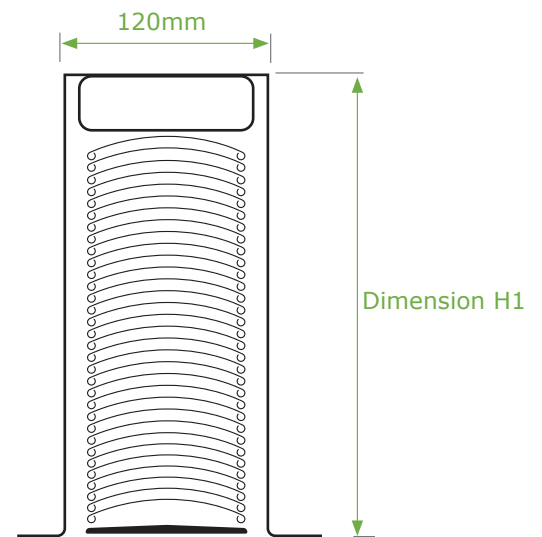

Trojan recessed into opening above window