

# Trojan AV90

## External Audio Visual Venetian Blinds

### ARG90

Audio visual 90mm slat with gearbox control.

### AEG90

Audio visual 90mm slat with motorised control.

## Technical Specification

### Slats

Made from special grade aluminium alloy that is designed to give the greatest flexibility with maximum resistance to corrosion. They are roll-formed from pre-coated aluminium strip that has been specially treated before enamelling to give maximum bond between metal and the finish. The enamel, in a wide range of colours, is then baked to give a finish highly resistant to scratching, fading and cracking. The profile is 92 mm wide x 0.45mm thick with a Z shaped profile.

### Head Rail

Roll formed steel section 58mm wide x 56mm deep which conceals the operating mechanism and has a galvanised finish.

### Tilt and Raise Rod

Rigid 14mm round extruded aluminium fitted through tape rolls in the headrail. Of a dimension to ensure minimal deflection across the width.

- 1 Slat
- 2 Headrail
- 3 Bottom Rail
- 4 Ladderbraid
- 5 Lift Tape
- 6 Top Fixing Bracket
- 7 Motor
- 8 Side Guide
- 9 Side Guide Bracket
- 10 Guide Pin

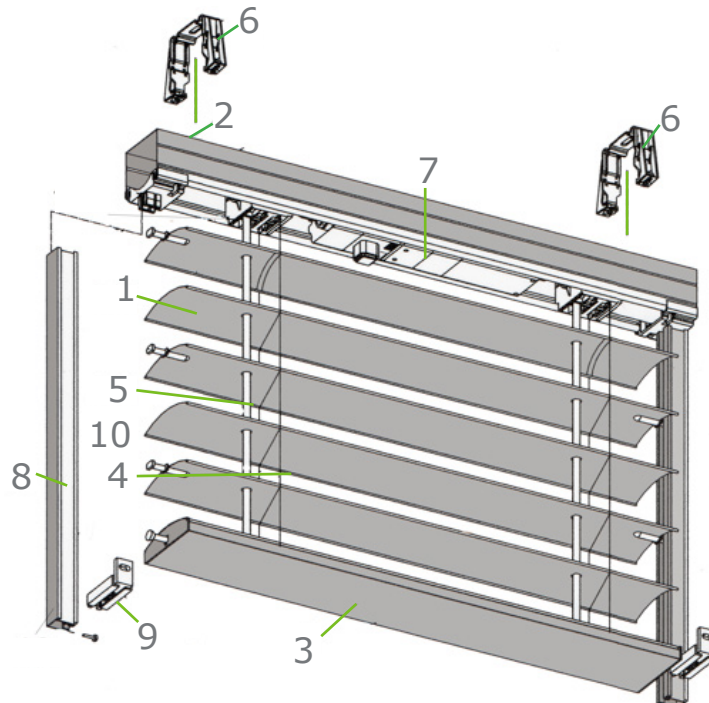

Component Descriptions complying with EN12246

## External Audio Visual Venetian Blinds

**Bottom Rail** Extruded aluminium section 85mm wide x 17mm deep in RAL colour to match the slat. End caps are black or grey.

**Ladderbraid** External grade mini visible Trevira® braid available in black and grey. It is shrinkproof, rotproof and guaranteed fade resistant. Spacing between ladders is 68mm.

**Lift Tape** 6mm wide polyester lift tape in black or grey that is weather, shrink, stretch, break and fold resistant.

### Side Guides

Trojan slats are guided by extruded aluminium sections. All profiles have nylon inserts in both sides of the extrusion as a noise buffer.

- Standard guide ES20 with bracket groove is for face fixing.
- Type RE41 guide has a re-informed round profile.
- Type EF40 guide is a reinforced profile that allows greater span between fixings.
- Box support guides are particularly suited to retro-fit applications as all of the fixing points are on the side guides. The blind and fascia box are supported on the guides both simplifying the installation procedure and reducing the impact of the assembly on the building structure.

All are available as a centre (double) guide

### Side Guide Pins

Nylon guide pins are fitted to alternate ends of the slats to allow movement of the slatting area. The pins are silver.

### Performance

Trojan AV90 meet the performance requirements of EN13561 Class 3 for wind resistance which is Beaufort scale force 6 (strong wind) a wind speed of 49 km/h

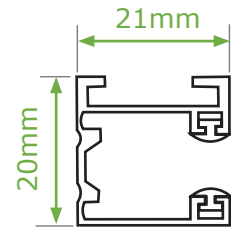

ES20 Standard guide

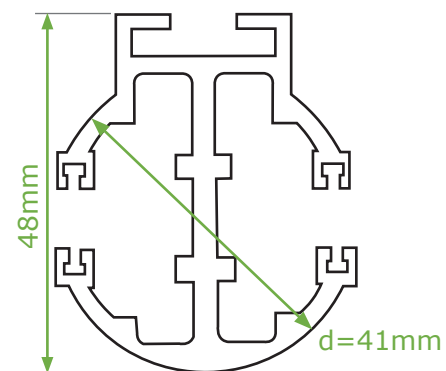

RE 41 Box support guide

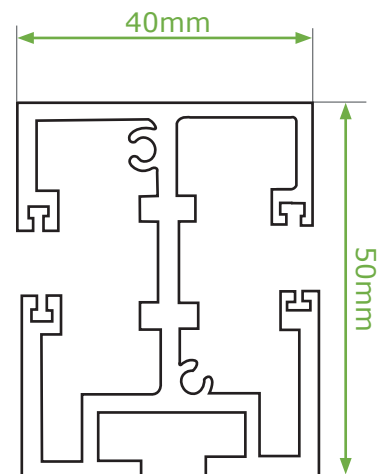

EF40 Box support guide

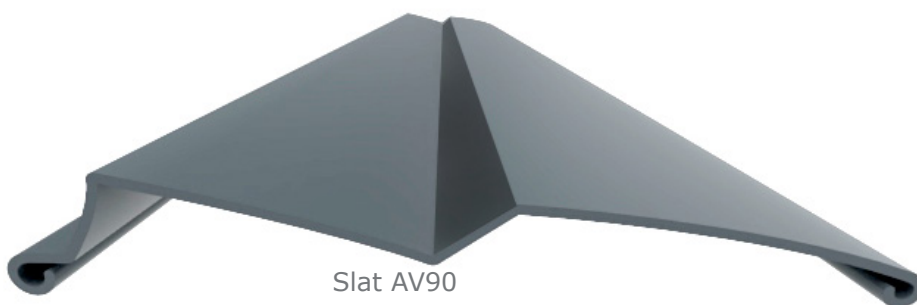

Slat AV90



## External Audio Visual Venetian Blinds

### Operation

Trojan blinds are mono controlled with both tilt and raise/lower on one motor or gearbox. The sequence of the operation is that it first tilts to the closed position and then lowers. Reversing the operation causes the blind to first tilt to the opposite closure before raising. Thus the blind can be fully tilted at any point between fully lowered and fully raised by reversing the control. The slat angle can be also factory set to lower in the working (45°) position.

### Motorised Control AEG90

#### Motors

The motor is located in the blind headrail. It is 240v single phase with a maximum current requirement of less than 1 amp. It is supplied with an 80cm "flying" lead. This should be connected to a junction box or plug adjacent to the headrail to facilitate removal for maintenance. 110v motors are also available.

#### Wiring

The motor has a four core cable Neutral, Earth, Supply for lower and Supply for raise. Wiring diagrams are available for all standard control options.

#### Switches

A range of switches is available. Before using any other type of switch it is important to confirm with us that it is compatible to maintain the motor manufacturers warranty.

### Manual Control ARG90

#### Gear Box

Hardened steel gears running in Zamac casings which produce a smooth operation which is robust and maintenance free. The unit is located at one end of the headrail.

#### Limit Adjuster

A nylon traveller that if fitted on the tilt shaft with an adjustable stop that is pre-set to prevent damage from over winding.

#### Universal Joint

A drive from the gearbox exits from the back of the headrail through the building to a universal joint. A 20mm hole is required through the building to allow clearance for the drive. The standard joint drive type GP45 exits at 45° to a nickel plated mounting 22mm wide x 85mm high on the room side. A 90° drive type GP90 is also available.

#### Operating Rod

The joint is connected to 15mm dia. rod with a cranked end. A nylon magnetic clip retains the rod when not in use.

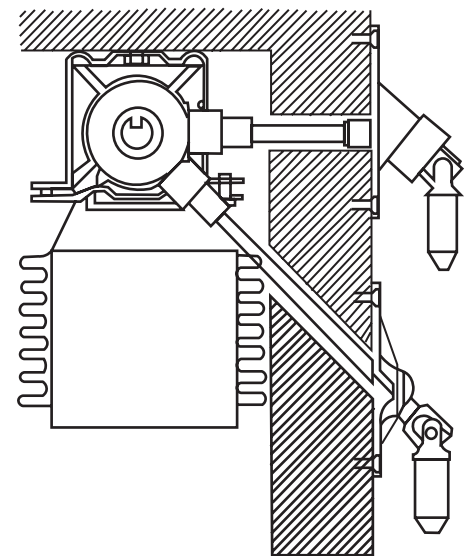

Manual Operation



## External Audio Visual Venetian Blinds

### Standard Fascia Profiles

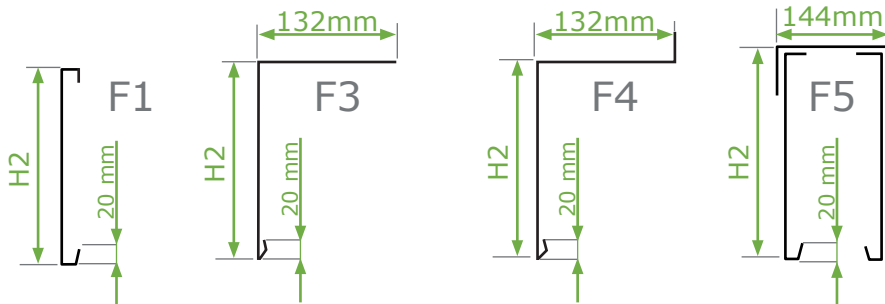

### Extruded guide supported

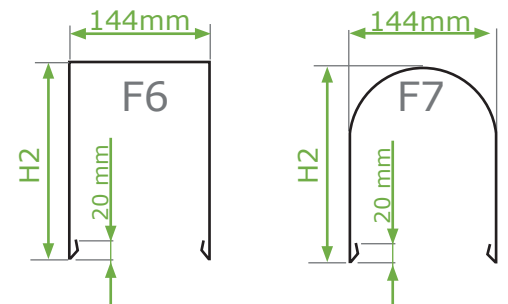

## Boxing or Fascia

Ideally the blind is recessed into an opening above the window head. A minimum opening width of 120mm is required to allow access, this dimension should not be exceeded. The depth required (H1) is shown on the stacking chart. On existing buildings a fascia or box will be required to house the blind when retracted. There are 6 profiles with standard depths (H2). Extruded aluminium guide support boxing is available in styles F6 and F7. This is supported on the side guides. Stacking dimensions and dimensions for blinds in standard boxing.

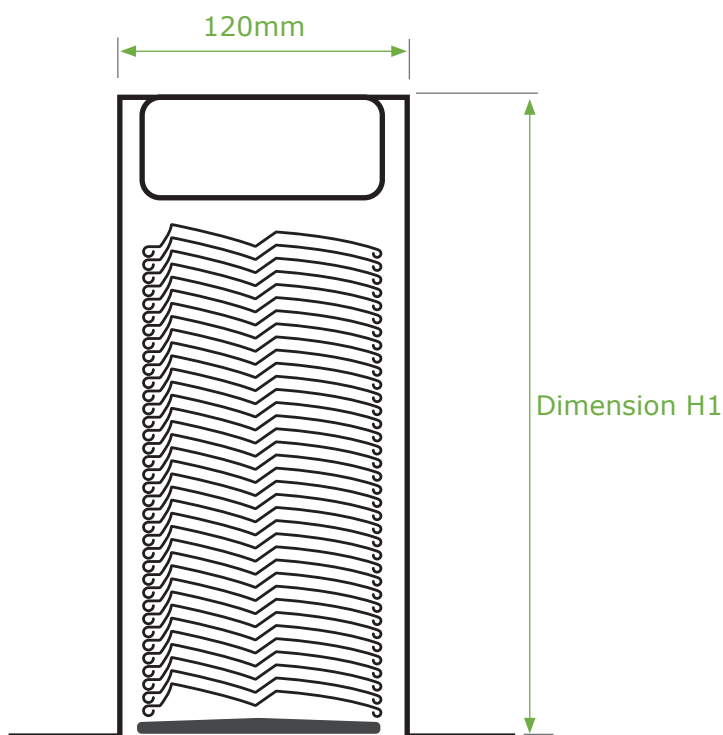

Trojan recessed into opening above window

Dimension Chart			
MinWidth (mm)	Max Width (mm)	Max drop (mm)	Max Sq. Area

#### AEG90

720	4500	5000	14
-----	------	------	----

#### ARG90

655	4500	5000	8
-----	------	------	---

#### Blind type AVEG90/AVRG90

Drop size (mm)	Stacking Height (mm) Dimension H1	Standard Boxing or Fascia height (mm) Dimension H2
800	130	200
1000	140	200
1200	160	200
1400	170	200
1600	190	200
1800	200	200
2000	220	250
2200	230	250
2400	250	250
2600	260	300
2800	270	300
3000	290	300
3200	300	300
3400	310	340
3600	330	340
3800	340	340
4000	360	370
4200	370	370
4400	390	440
4600	400	440
4800	420	440
5000	430	440